

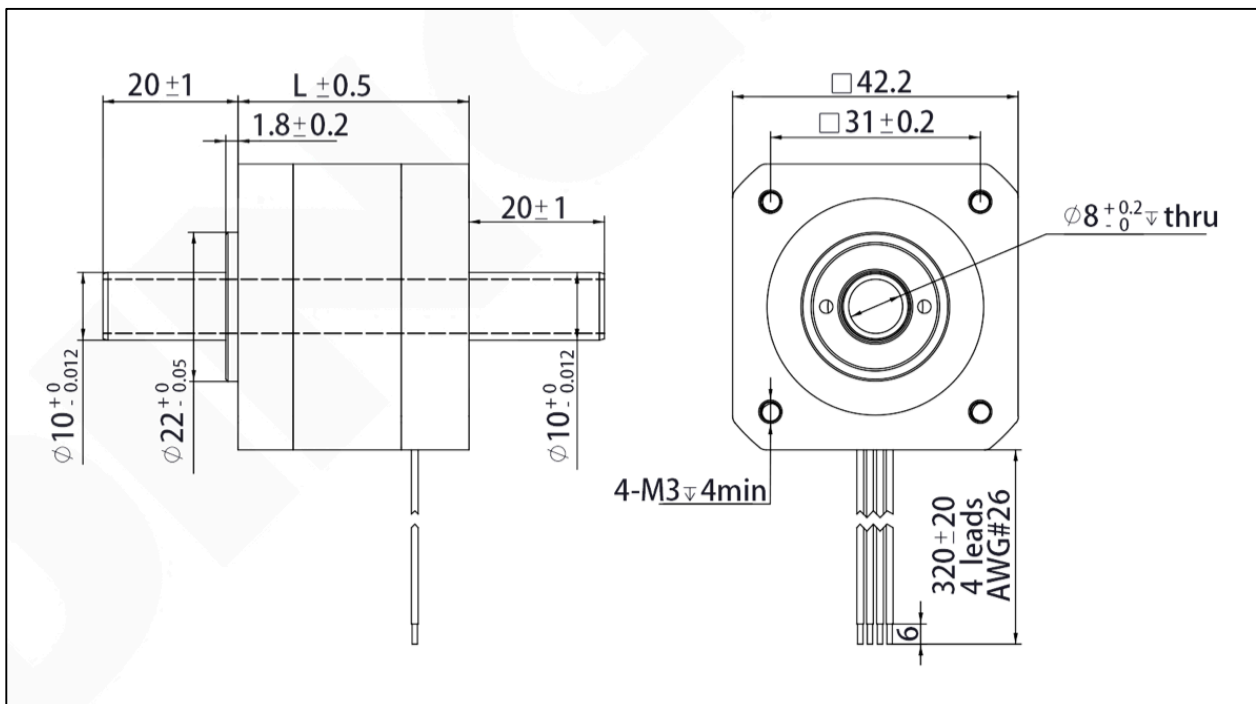

• Motor Characteristics

Motor	Rated Voltage (V)	Current (A)	Resistance (Ω)	Inductance (mH)	Holding Torque (Nm)	Detent Torque (Nm)	Motor Length « L » (mm)
MOT1734-10-H-x	3,8	1,0	3,8	5,0	0,31	0,014	34,1
MOT1748-25-H-x	2,5	2,5	1,0	1,8	0,56	0,018	48,1

• Dimensional Drawings



Torque Performance Curves

